

SPECIFICATIONS

GENERAL:

The surface drainage system shall be FoodSafe Trench Drain - V-Bottom, to be used with trench grates as manufactured by FoodSafe Drains.

MATERIALS:

14 ga. T304 Stainless Steel, T316 Stainless Steel

SLOPE:

0.5% Standard

GRATES:

Bargrate with Optional Serration/Antislip Design

DESIGN OPTIONS:

Material (\$): SS 304(5), SS 316(6)
End (*): Open (0), End Cap (1), Flash Nipple (5)
Trench Grate Height (^): 6mm w Spacer to 51mm
Trench Grate Width (#): 152mm, 203mm, 254mm, 305mm, 356mm, 406mm
Outlet Diameter: 76mm, 102mm, 152mm
Standard Lengths: 2.268m or 1.524m
(Custom Lengths Available)

LOAD CLASS:

A15 to E600 Available.

INSTALLATION:

The FoodSafe Trench Drain - V-Bottom shall be installed in accordance with the manufacturer's installation instructions and recommendations. Trench sections are manufactured with leveling bars and flanges to secure the drain within the concrete slab.

TYPICAL MODULAR LAYOUT OF A FOODSAFE TRENCH DRAIN - V-BOTTOM SYSTEM

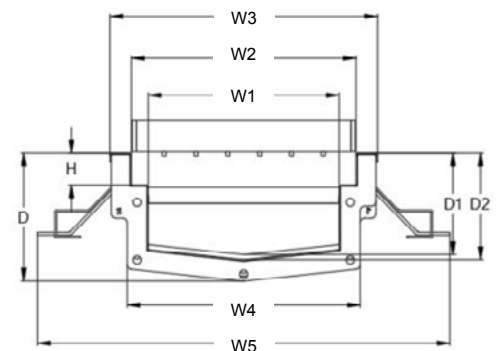
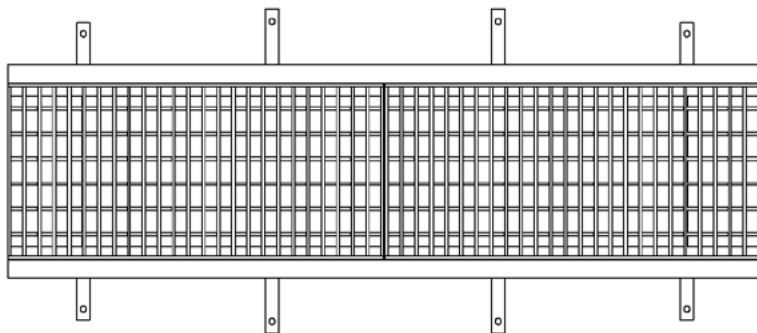
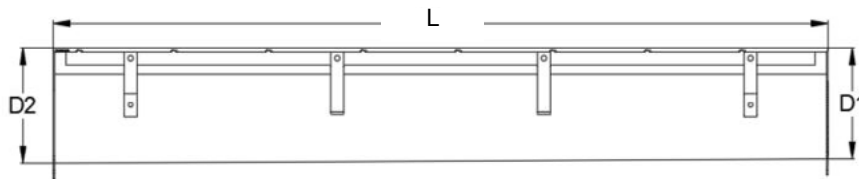

DRAIN CHANNELS NOTE: Also available with 90° sections, 'T' sections, for all of the depths specified below.

DESCRIPTION	PART NO.	INVERT SHALLOW (MM)	INVERT DEEP (MM)
FSD TRENCH - V-BOTTOM 102	FTV5*\$\$-102	152	178
FSD TRENCH - V-BOTTOM 203	FTV5*\$\$-203	178	200
FSD TRENCH - V-BOTTOM 304	FTV5*\$\$-304	200	224
FSD TRENCH - V-BOTTOM 405	FTV5*\$\$-405	224	248
FSD TRENCH - V-BOTTOM 506	FTV5*\$\$-506	248	271
FSD TRENCH - V-BOTTOM 607	FTV5*\$\$-607	271	295
FSD TRENCH - V-BOTTOM 708	FTV5*\$\$-708	295	319
FSD TRENCH - V-BOTTOM 809	FTV5*\$\$-809	319	343
FSD TRENCH - V-BOTTOM 9010	FTV5*\$\$-9010	343	367

TRENCH DRAIN CATCH BASINS ARE AVAILABLE IN ANY CUSTOM DIMENSIONS

SPECIFYING ENGINEER IS RESPONSIBLE FOR CONCRETE ENCASEMENT AND REINFORCING BASED UPON APPLICATION AND LOCAL CODES. FOODSAFE DRAINS RESERVES THE RIGHT TO CHANGE THE PRODUCT AND SPECIFICATIONS WITHOUT NOTICE